

LOGISTICS SUPPLIER MANUAL

Version 4.0

Contents

Preface	6
Supplier Manual Scope	6
1 Information management in logistics	6
1.1 SUPPLIER - BOSCH communication	6
1.1.1 Contact	6
1.1.2 Availability	6
1.2 Information transmission	7
1.2.1 Business processes with EDI	7
1.2.2 EDI link options	7
2 Control concepts and order processing	7
2.1 Control concepts	8
2.1.1 KANBAN	8
2.1.2 VMI including consignment	8
2.1.3 Call-off PO ROP Pull	9
2.2 Flexibility and release periods.....	10
2.2.1 Production and material releases	10
2.2.2 Minimum order quantities	10
2.2.3 Flexibility	10
2.2.4 Start-up and phase-out control	11
3 Packaging	11
3.1 Packaging specifications.....	11
3.1.1 Packaging design criteria	11
3.1.2 Responsibilities and definition of packaging specification	11
3.1.3 Permitted and non-permitted materials	12

3.1.4	Delivery specifications	13
3.1.5	Requirements for electrostatic discharge (abbr.: ESD) protection	13
3.1.6	Corrosion prevention and moisture control	13
3.1.7	Packaging for hazardous goods	14
3.2	One-way packaging	14
3.2.1	Specification	14
3.2.2	Procurement	14
3.2.3	Specific requirements depending on transportation type	14
3.3	Returnable packaging	15
3.3.1	Specification depending on type of returnable packaging	15
3.3.2	Empties management	16
3.3.3	Provision and storage of BOSCH-returnable empties	16
3.3.4	Repairs and scrapping	16
3.3.5	Cleaning	17
3.3.6	Labeling of BOSCH-returnable packaging by the SUPPLIER	17
3.3.7	BOSCH standards for returnable SLC	17
3.3.8	Adapter pallets and roller carriages	17
4	Transport logistics	18
4.1	Basic information on shipping from SUPPLIER to BOSCH	18
4.1.1	Transportation companies, couriers, and package shipments	18
4.1.2	Packages and HUs	18
4.2	Shipping and transportation documents	18
4.2.1	Shipping documents	19
4.2.2	Transport documents	19
4.3	Labeling of products	20
4.4	Transport notification	21
4.4.1	Transports not processed through BOSCH TMC	21
4.4.2	Transports processed through BOSCH TMC	21
4.4.3	Special arrangements for transportation of critical goods	21
4.5	Label for sample parts	22
4.6	ASN	22
4.7	Shipping process	22
4.8	Security in goods transportation	22

5	Special transports and variation management	23
5.1	Special transports	23
5.2	Variation management	23
5.3	Risk and crisis management in logistics	23
5.3.1	Background	23
5.3.2	Definition, tasks, and objectives	24
6	Logistics quality	24
6.1	Definition	24
6.2	Logistics complaints	24
6.3	SUPPLIER Result Assessment (abbr.: LEB) – Logistics	25
6.4	Controlling of logistics performance by SUPPLIER	25
7	Further developments in logistics	26
8	Index of abbreviations	27
9	Definition of terms	28
10	Appendices	30
10.1	Appendix 1: Delivery matrix: Central requirements for cooperation in logistics.....	30
10.2	Appendix 2: Transport Order (TO)	32
10.3	Appendix 3: Label	33
10.3.1	Introduction	33
10.3.2	Labeling standards in compliance with VDA 4902/ODETTE	33

Index of Figures

Figure 1: Permitted and non-permitted materials	13
Figure 2: Series B1 for deliveries without external carton	15
Figure 3: Series B3 for deliveries without external carton	15
Figure 4: Cleaning Responsibility by region.....	17
Figure 5: Example roller carriage type 600x400mm	18
Figure 6: Example adapter pallet	18
Figure 7: Regional standards for shipping documents	19
Figure 8: Format and attachment of product tags.....	20
Figure 9: Index of abbreviations.....	28
Figure 10: Definition of terms	29
Figure 11: Standard delivery concepts.....	30
Figure 12: Standard delivery concepts continued.....	31
Figure 13: Example of TO	32
Figure 14: Main product label for original packaging (pallet, pallet cage) / The content of the label is shown as an example	33
Figure 15: Secondary labels for secondary packaging (SLC, carton ...) / The content of the label is shown as an example.	34
Figure 16: Binding and optional fields.....	35

Preface

Competition in national and international markets has intensified significantly in recent years. Increased customer expectations in terms of quality and flexibility mean that our company and the entire supply chain is faced with increasingly demanding challenges.

Traditional logistics has turned into an integrated, customer-focused management function, which is increasingly a strategic success factor in our company's competitiveness. The companies in the Bosch Group depend on cooperation with reliable, expert, and customer-focused suppliers.

Supplier Manual Scope

This supplier manual sets out the conditions for delivery of products by the SUPPLIER (as defined in [Chapter 9](#)). The rules it contains are applicable as a supplement to the agreements made with the SUPPLIER relating to the delivery of products (e.g. EZRS corporate agreement, A-supplier agreement, multi-year contract, (price) agreements, orders; the "delivery contract").

All companies of the Bosch Group (all companies directly or indirectly controlled by Robert Bosch GmbH ("BOSCH")) are entitled to apply the regulations set out in this supplier manual in its supplier logistics processes with the SUPPLIER, or its respectively responsible group companies (companies affiliated to SUPPLIER pursuant to § 15 AktG), from whom they purchase products.

The SUPPLIER is responsible for the quality of their products and for compliance with the requirements and rules set out in this supplier manual.

Deviations from or additions to this supplier manual (e.g. to take into account special requirements for the BOSCH plant supplied (as explained in [Chapter 9](#)) or for the relevant BOSCH division) can be agreed upon in writing (as defined in [Chapter 9](#)) between the SUPPLIER and BOSCH.

1 Information management in logistics

Constructive cooperation between the SUPPLIER and BOSCH requires targeted communication.

The key elements of this are:

- ▶ Prompt and unsolicited information in case of changes to any circumstances relating to the supply relationships.
- ▶ Compliance with and monitoring of agreements made.
- ▶ Use of state of the art communication methods.

1.1 SUPPLIER - BOSCH communication

1.1.1 Contact

The SUPPLIER and BOSCH name responsible contact persons. The SUPPLIER will also name a deputy and line manager, in each case specifying the name, position, e-mail address, telephone number, and mobile phone number, along with an emergency telephone number (the "emergency telephone").

The communication language is either the language of the BOSCH plant supplied or English.

1.1.2 Availability

The contact designated by the SUPPLIER (or their deputy) must be available on working days (as defined in [Chapter 9](#)) during normal local working hours (at least from 8:00 to 16:00 - local time for the SUPPLIER in each case) and is communicated to the BOSCH contact (as defined in [Chapter 9](#)).

Outside normal local working hours, the SUPPLIER must be available using the emergency telephone during the production hours of the BOSCH plant supplied. The emergency contact reached using the emergency telephone must be authorized to make decisions on production and shipping (particularly the organization of special transports).

1.2 Information transmission

The objective is an integrated data system between BOSCH and the SUPPLIER, with no manual interfaces (media breaks).

Therefore, transmission of information via Electronic Data Interchange (abbr.: EDI) is a prerequisite for a supply relationship with BOSCH. The SUPPLIER shall use EDI to receive information from BOSCH and to send information to BOSCH. If the SUPPLIER has no existing EDI link to BOSCH, a schedule for introduction of EDI is agreed and is implemented by the SUPPLIER.

The technical requirements and approved message formats are agreed in the EDI contract. Further information can be found in the BOSCH EDI brochure, which can be downloaded from www.edi-service.bosch.com.

1.2.1 Business processes with EDI

The following business processes, in particular - where they are used - are to be carried out with EDI support:

- ▶ Transmission of the call offs (as defined in [Chapter 9](#)) from BOSCH to the SUPPLIER.
- ▶ Transmission of the advanced shipping notification (abbr.: ASN) from SUPPLIER to BOSCH.
- ▶ KANBAN call offs.
- ▶ Transmission of vendor managed inventory (abbr.: VMI) information.
- ▶ For consignment warehouse processing: self-billing invoice (abbr.: SBI) (if legally permitted, country-specific) and stock movement list (inventory report message).
- ▶ Transmission of confirmed dates/quantities from SUPPLIER to BOSCH.
- ▶ Empties management

1.2.2 EDI link options

One of the two types of EDI link described below is to be used:

Classic EDI

Classic EDI includes a specific IT infrastructure on the supplier and customer side for processing electronic message formats. Classic EDI is designed to support direct communication between Enterprise Resource Planning (abbr.: ERP) systems with no media break, i.e. the information is exchanged between the supplier and customer side information processing systems with no additional manual recording. When using classic EDI, the consistency of the system (ensuring correct and complete data transfer) must be guaranteed for the entire planning, production, and shipping process by the SUPPLIER.

WebEDI (SupplyOn)

With WebEDI, information is exchanged between the supplier and customer via an Internet platform. Information is exchanged between the SUPPLIER and BOSCH via the SupplyOn Internet platform (available at <http://www.supplyon.com>).

When using WebEDI, the SupplyOn server processes the EDI data transmitted by BOSCH as web forms and provides them to the SUPPLIER along with message forms for data recording. To operate the system, the SUPPLIER requires a computer with Internet access.

The SUPPLIER can use SupplyOn to create the shipping documents. Information on labeling of the products from the call-off is to be transferred to the shipping documents.

2 Control concepts and order processing

This chapter sets out the requirements for receipt and processing of call-offs, and the scheduling of BOSCH requirements in the SUPPLIER's production and delivery schedules.

BOSCH will notify the SUPPLIER of requirements according to the control concept used by BOSCH. These notifications will partly be issued as non-binding forecast requirements (preview) and partly as production and material releases.

Based on this the SUPPLIER will ensure that:

- ▶ Their sub-suppliers deliver the appropriate primary material
- ▶ Their production capacity is sufficient for the notified preview, and
- ▶ Deliveries are made to BOSCH on time

2.1 Control concepts

BOSCH aims to make the entire supply chain from the SUPPLIER to BOSCH as lean and low-waste as possible. Therefore, consumption-oriented control systems are preferred at BOSCH ("Only deliver what the previous value chain has actually consumed."). Which control concept is most suitable from this perspective and is therefore to be used is agreed by BOSCH with the SUPPLIER.

In procurement, a distinction is made between the following control concepts:

1. KANBAN
2. VMI including consignment
3. Call-off | purchase orders (abbr.: PO) | Reorder point pull (abbr.: ROP pull)

The above series represents a line of preference: The subsequent control concept in this series is only to be used if the preceding control concept cannot be realized or is not feasible.

See details on the control concepts in this [chapter 2](#) and in [annex 1](#). The SUPPLIER implements the requirements of the respective control concept. These are based on economic perspectives. If market conditions do not permit the implementation of individual requirements, an additional agreement is to be drawn up in consultation with the logistics of the affected division and the BOSCH plant logistics.

2.1.1 KANBAN

Using KANBAN, the preferred stock level concepts are ship to line (abbr.: STL), ship to supermarket or localization by the SUPPLIER (plant or warehouse). The KANBAN system is a card-based instrument for controlling the information flow and materials procurement. The next delivery is triggered by withdrawal of a defined quantity of material from supply areas (supermarkets) close to production. Consumption is indicated by release of a KANBAN card, which is seen as the re-order. The electronic KANBAN call-off (*JIT call*) is transmitted using EDI ([see chapter 1.2](#)).

In addition to the short-notice KANBAN call-offs, the SUPPLIER receives a rolling preview showing production and material releases ([see chapter 2.2.1](#)). However, the SUPPLIER only supplies on the basis of the KANBAN call-offs received.

Details (e.g. the relevant part numbers for which KANBAN is to be used; delivery conditions, frequencies and shipping details) are agreed in the KANBAN contract.

2.1.2 VMI including consignment

VMI

When using VMI, the traditional two-way material requirements planning for the flow of products from the SUPPLIER to BOSCH (SUPPLIER: order planning, BOSCH: customer planning) is replaced by a single material requirements planning. The SUPPLIER holds the inventories within the stipulated minimum and maximum inventory levels by acting in a proactive and anticipatory manner and taking into account transport times and delivery windows. SUPPLIER material requirements planning is based on the information on inventories and the predicted requirements from BOSCH, which BOSCH regularly communicates to the SUPPLIER.

The VMI Monitor in SupplyOn is the standard tool used by BOSCH and enables the SUPPLIER and BOSCH to have the same view of relevant VMI information at all times.

BOSCH provides the information on inventories, stock movements, and gross requirements (as defined in [Chapter 9](#)) (the "VMI information") on a daily basis. The SUPPLIER receives the VMI information from BOSCH and is independently responsible for holding inventories between the stipulated lower and upper inventory limits. The data in the VMI Monitor is definitive. The SUPPLIER does not receive any separate call-offs.

Production and material releases for products controlled using VMI are defined separately (e.g. in the VMI contract).

If requested by BOSCH, the SUPPLIER must notify BOSCH with information on the planned deliveries: Also, for each delivery, the SUPPLIER sends an ASN to the BOSCH plant supplied ([see section 1.2.1](#)).

The arrangements in the BOSCH VMI manual (which can be downloaded from www.bosch.com > Purchasing and Logistics > Downloads > Logistics > *Vendor Managed Inventory (VMI)*) are applicable.

Details (e.g. relevant part numbers for use of VMI are to be used; upper and lower inventory limits) are agreed in the VMI contract.

Consignment

When using consignment, the SUPPLIER remains the legal and economic owner of the consignment goods until they are withdrawn from the consignment warehouse. The consignment warehouse can be located at BOSCH or at a logistics service provider (abbr.: LSP) engaged by BOSCH. Warehouse management is carried out by BOSCH or a LSP engaged by BOSCH.

Unless otherwise agreed, transportation of the products to the consignment warehouse is arranged by BOSCH.

The SUPPLIER must comply with the tax obligations resulting from operation of the consignment warehouse (e.g. value added tax (abbr.: VAT) registration) under the applicable legislation and provide BOSCH with the necessary information.

Control of the consignment warehouse inventory and information exchange are carried out using VMI ([see section 2.1.2](#)). Only in exceptional cases and with the consent of BOSCH, the consignment warehouse inventory is controlled using delivery call-offs.

Details (e.g. relevant part numbers, which are to be used for consignment; maximum storage time, and location of the consignment warehouse) are agreed in the consignment contract.

2.1.3 Call-off | PO | ROP Pull

Call-offs are communicated on a rolling basis. They are updated regularly and contain order and master data (e.g. quantities and dates) with a horizon of several months. Master data relevant for call-offs must be communicated by the SUPPLIER (e.g. value added tax identification number (abbr.: VATIN.)). The last call-off is relevant and supersedes previous call-offs.

In exceptional cases, PO are transmitted by agreement (e.g. orders for samples, operating supplies (abbr.: HIBE), machine accessories and replacement parts (abbr.: MAZE)).

In the Power Tools (abbr.: PT) division, a control concept is used in which the binding call-off is transmitted using a PO and the rolling preview using call-offs (ROP pull).

Order processing and tracking

The delivery dates specified in the call-off or PO are binding dates for receipt of the goods in the BOSCH plant supplied. The SUPPLIER ensures delivery on the incoming date by determining the correct shipping date from the SUPPLIER taking into account transportation times and the applicable Incoterm (as defined in [Chapter 9](#)). Different arrangements can be made (e.g. dates specified in the call-off match the shipping date (dispatch date) ([See Chapter 7](#))). The SUPPLIER checks the incoming order for completeness, accuracy, and plausibility (e.g. SUPPLIER name, part number, quantity, date) and notifies BOSCH immediately of any discrepancies. The SUPPLIER operates a continuous internal order tracking system. The SUPPLIER is able to provide information about production progress at any time. The SUPPLIER ensures that sub-suppliers operate a transparent order tracking system.

2.2 Flexibility and release periods

2.2.1 Production and material releases

Periods for production and material releases can be set out in the call-off or the delivery contract, for example. For call-offs, periods mentioned in the production and material releases start with the date of the call-off. For VMI, they start with the transmission time of the VMI information. If the market situation requires, the release periods can be temporarily shortened or extended by BOSCH. If the issued releases are demonstrably insufficient to maintain delivery capability, BOSCH can extend the release period at the request of the SUPPLIER. All changes to production / material releases must be made in writing.

Required quantities beyond the production and material release periods are non-binding planned figures (preview), which the SUPPLIER uses as a basis for their production capacity.

The production and material releases are governed by the terms of the delivery contract. Unless agreed otherwise, the following shall apply:

Subject to alternative agreements, BOSCH can move the delivery date for each call-off with no penalty. BOSCH may also terminate call-offs. In the event of termination, BOSCH only has to pay compensation if no appropriate replacement call-offs were granted. The compensation is limited upon selection by BOSCH to (a) the acceptance and payment or (b) the adoption of scrapping costs for contract products or material for which a binding production release or material release was issued. For the scrapping costs, the purchase prices of the SUPPLIER are crucial. The compensation requires proof from the SUPPLIER that they cannot otherwise use the finished products or the material and cannot cancel material purchase orders. For semi-finished contract products, BOSCH only has to take on the proportional costs according to the production status or the proportional scrapping costs. The SUPPLIER is required to minimize the costs as far as possible in the event of a termination.

2.2.2 Minimum order quantities

Minimum order quantities are not permitted unless BOSCH agrees to a minimum order quantity in exceptional situations.

Where possible, BOSCH orders quantities optimized in terms of logistics costs wherever possible and works on the basis of overall cost optimization and total cost of ownership (abbr.: TCO), taking into account costs incurred by both BOSCH and the SUPPLIER. The quantities can be less than a full handling unit (abbr.: HU) / packing unit.

If it is economically necessary for the SUPPLIER to produce a certain quantity, the SUPPLIER informs BOSCH of this. If this is accepted by BOSCH, this can also be reflected as a production release by BOSCH upon request from the SUPPLIER. From one production batch several BOSCH plants may be supplied. .

2.2.3 Flexibility

BOSCH will take into account transport times and, where possible, order in such a way that additional costs to both parties resulting from the order are avoided. If additional costs resulting from the order are unavoidable, they will be borne by BOSCH or the SUPPLIER according to who is responsible for those costs being incurred (causation principle).

Additional costs to the SUPPLIER resulting from the order may not be claimed if BOSCH moves the delivery date for an order that has not yet left the SUPPLIER plant.

Flexibility (in terms of the delivery contract regarding individual contracts, call-offs and capacity reserve) is subject to the terms of the delivery contract. Unless otherwise agreed in the delivery contract:

Unless otherwise agreed, call-off's are deemed respectively accepted by the SUPPLIER if the SUPPLIER does not object to them in writing within two (2) working days of receipt. An objection to the call-off by the SUPPLIER shall only be allowed in case the legally binding order (production release) exceeds the previous non-binding preview from BOSCH by more than 20 percent. For an agreed multi-year contract (abbr.: MYC), a capacity reserve of (up to) 33 percent must be implemented for its duration, based on the preview transferred by BOSCH and the underlying shift model. This capacity reserve serves to buffer peak requirements and must therefore be implemented in the short term without additional costs and process changes by the SUPPLIER.

2.2.4 Start-up and phase-out control

BOSCH expects increased flexibility from the SUPPLIER in the start-up and phase-out phases. The start-up and phase-out quantities and dates must be agreed between BOSCH and the SUPPLIER in good time. The control concept is to be discussed and, if necessary, adapted based on the requirements of the individual situation.

3 Packaging

3.1 Packaging specifications

3.1.1 Packaging design criteria

The packaging between BOSCH and the SUPPLIER is to be designed based on economic, quality, and environmental criteria.

In terms of economic criteria, the packaging may not be of higher value than is absolutely necessary to safeguard the quality and integrity of the products during transportation to, storage and production at BOSCH. It must be ensured that the packaging employees or other persons are protected from hazards caused by the products themselves (e.g. hazardous goods). The packaging itself may not cause any hazard for persons (e.g. protruding nails). From an environmental perspective, recyclable and unmixed materials are to be used, which are environmentally compatible and easy to dispose of, and are labeled in compliance with the disposal business specifications.

Further requirements for packaging:

- ▶ Easy handling during opening and closing, and for repacking operations.
- ▶ Stackable loading units: dynamic stacking factor (as defined in [Chapter 9](#)) at least 2 (1+1).
- ▶ Optimum filling of packages and loading units to optimize transport costs
- ▶ Gross weight per loading unit (as defined in [Chapter 9](#)) maximum 1,000 kg.
In justified exceptional cases, a special approval can be agreed in consultation with the BOSCH contact.
- ▶ The gross weight per manually handled package (as defined in [Chapter 9](#)) is normally between 10 and 15 kg: alternative agreements can be made for specific requirements or due to regional regulations.
- ▶ For loading units with basic dimensions 1200x800 mm, the following preferred external dimensions apply for packages: 300x200 mm, 400x300 mm, or 600x400 mm. (See [section 3.2](#) and [section 3.3](#).)
- ▶ Loading units may not have any protruding or jutting labels or strips; in particular cartons must be dimensionally stable and have correctly folded covers.
- ▶ Mixed pallets are generally permitted. They must be clearly labeled as mixed pallets. Posting and unmixed storage must be possible with no additional costs (for example stackable (intermediate) load carriers). The use of mixed pallets must be agreed with the BOSCH contact. (See [section 3.1.4](#) and [section 4.1.2](#).)
- ▶ International symbols should be used to label goods that are subject to special handling.
- ▶ Specific requirements apply for the North American Free Trade Agreement (abbr.: NAFTA) in accordance with the NA Supplier Packaging & Labeling Standards, see link:
Internet: www.bosch.com > Purchasing & Logistics > Downloads > Logistics > Regional Regulations.

3.1.2 Responsibilities and definition of packaging specification

The packaging is to be defined at an early stage - if possible during the development phase - in agreement between the BOSCH plant supplied and SUPPLIER. Bosch standard or standardized packaging (e.g. German Association of the Automotive Industry (*Verband der Automobilindustrie*; abbr.: VDA) is preferred.

Before release of the packaging by BOSCH, the SUPPLIER needs to adequately test the packaging in consultation with the BOSCH contact (e.g. transport tests, behavior when washing). BOSCH and the SUPPLIER agree the final product-specific packaging in the form of a packaging specification, which will be generally binding for future deliveries.

In exceptional cases an alternative packaging (as defined in [Chapter 9](#)) can be used, but only in consultation with, and after release by BOSCH. This must also be tested in advance. Release of the packaging specification does not absolve the SUPPLIER from their quality responsibility.

Compliance with the packaging specification and agreement of alternative packaging is included in the SUPPLIER assessment. Unreleased variations and quality defects attributable to the SUPPLIER are recorded as logistics failures (see section 6.2) and can result in complaints in accordance with the 8D process. BOSCH can charge the SUPPLIER for any additional costs arising within this context.

The SUPPLIER will support any changes to existing packaging requested by BOSCH during series delivery. The SUPPLIER has an obligation to independently raise any requirements in terms of quality and potential optimizations based on their specific product knowledge.

3.1.3 Permitted and non-permitted materials

The following overview shows the possibilities of using different packaging materials in a table. The use of prohibited materials is to be prevented.

Composite materials (as defined in Chapter 9) General		
General	✓	-
	0	Only with special approval from the BOSCH contact
	✗	-
Plastics		
One-way	✓	Polyethylene (abbr.: PE), Polypropylene (abbr.: PP), Polystyrene (abbr.: PS), Acrylonitrile-butadiene-styrene (abbr.: ABS), Expanded Polystyrene (abbr.: EPS) (except EPS chips), Expanded Polyethylene (abbr.: EPE), Expanded Polypropylene (abbr.: EPP), Polyethylene Terephthalate (abbr.: PET); labeling according to DIN 6120 (German Institute for Standardization, <i>Deutsches Institut für Normung</i> ; abbr.: DIN)
	0	Polyvinylethene chloride (abbr.: PVC) only with special approval from the BOSCH contact
	✗	Polyurethane (abbr.: PUR), EPS chips
Returnable	✓	ABS, PE, PP, PS, PET, EPP, EPE Labeling in compliance with DIN 6120
	0	PVC only with special approval from the BOSCH contact
	✗	-
Films, bags, and sacks made of film	✓	PE with labeling in compliance with DIN 6120 recommended, sticker/label and adhesive tape from the same materials; <i>Intercept / Volatile Corrosion Inhibitor</i> (abbr.: VCI) - film as corrosion protection
	0	-
	✗	Sticker/label and adhesive tape from different materials
Paper and cardboard		
General	✓	Free of harmful paper manufacturing substances and labeled with Recycling symbol (abbr.: RESY)
	0	Non water-soluble coatings or adhesives, e.g. wax, paraffin, bitumen, and oil paper or impregnated papers and cardboards, fabric adhesive tapes, fiberglass-reinforced paper adhesive tapes are to be reduced to a necessary minimum. Use generally only after consultation and approval from the BOSCH contact
	✗	-
Corrosion protective paper	✓	VCI papers with demonstrated recycling capability with paper/cardboard and labeled with RESY symbol
	0	-
	✗	-
Tapes		
General	✓	PP, PET Labeling in compliance with DIN 6120 recommended
	0	Steel tapes and metal clamps <u>for heavy loads</u> only with special approval from the BOSCH contact
	✗	Steel tapes and metal clamps

Wood		
General	✓	International Plant Protection Convention (abbr.: IPPC) standard (only heat treatment) Moisture level < 20 % Country-specific requirements must be met, see Internet: https://www.IPPC.int , <i>International Standards for Phytosanitary Measures</i> (abbr.: ISPM)15: http://pflanzenegesundheit.jki.bund.de/index.php?menuid=48&reporeid=40
	0	-
	✗	IPPC standard (chemical pressure impregnation) Press board pallets (INKA pallets), coated and painted wood and wood wool
Padding and shock-absorbing materials		
General	✓	Usage is to be minimized as effectively as possible by adaptation of quantity of parts in packaging
	0	
	✗	Chips and filling materials made of foodstuffs (e.g. corn starch, straw, bark)

Figure 1: Permitted and non-permitted materials

3.1.4 Delivery specifications

The SUPPLIER must pack the packages unmixed - different modification / revision levels of products may not be combined in a package or in a loading unit.

The individual packages are to be combined by the SUPPLIER to form a transportable loading unit on the pallet and secured against slipping during transportation. The pallet must be designed as a 4-way pallet with three runners. For lower volumes, variations are to be agreed in advance with the BOSCH contact.

For delivery on pallets, the top layer must be flat. If the quantity to be packaged means that a stackable surface cannot be created, it should be filled up with empty containers. For one-way packaging, the SUPPLIER ensures stackability. At least the containers on the top layer are to be sealed with a cover. When ensuring stackability, the entire loading unit must be secured with at least two plastic tapes running all the way around the length. Pallet covers are to be used to prevent damage; plastic tapes may not be run around pallets without these.

The SUPPLIER shall ensure the traceability of the products it supplies. The systematic for traceability has to be showed to and agreed by BOSCH during contract review, i.e. with the offer or during technical discussion.

3.1.5 Requirements for electrostatic discharge (abbr.: ESD) protection

Components that are sensitive to electrostatic discharge (Electrostatic Discharge Sensitive Device; abbr.: ESDS) must be protected against charging and rapid discharge according to the classification of their damage risk. If no external protection is fitted, the ESDS component may not come into contact with any electrostatically chargeable materials.

It must be ensured at all times that ESDS components are not exposed to any risk in terms of ESD during transportation and storage. The SUPPLIER must strictly comply with the relevant requirements for ESD-proof packaging set out in DIN EN 61340-5-1.

All ESD packaging materials must be labeled with the ESD symbol.

The requirements for ESD packaging are determined by the relevant ESDS components to be packaged. The use and scope of ESD packaging are specified by BOSCH in agreement with the responsible ESD coordinator and SUPPLIER.

3.1.6 Corrosion prevention and moisture control

Materials or products susceptible to corrosion must be protected during transportation and storage according to the prevailing external conditions (for example high relative humidity or for sea transportation). For example, desiccant bags, VCI paper and corrosion protection using *Intercept* technology are suitable.

3.1.7 Packaging for hazardous goods

For each location and material number, the packaging for hazardous goods must be approved by the BOSCH hazardous goods officer or an LSP engaged by BOSCH before the first shipment of products. This also applies for pilot series and sample deliveries. The corresponding warning symbols must always be attached by the SUPPLIER clearly visibly to the packaging. The SUPPLIER must always comply with the laws and regulations applicable for hazardous goods in the respective countries.

3.2 One-way packaging

3.2.1 Specification

One-way packaging is specified by the SUPPLIER in agreement with the BOSCH contact. The SUPPLIER will ensure that the packaging adequately protects the packaged goods from dirt, environmental effects (e.g. corrosion protection), mechanical influences and damage. A high packing density is to be guaranteed to keep down the costs of transportation and packaging components.

3.2.2 Procurement

The SUPPLIER procures the agreed one-way packaging (also includes packaging aids) at his own expense. Usually, the packaging costs are compensated by BOSCH via the product price. The packaging costs will be indicated separately in the quotation.

3.2.3 Specific requirements depending on transportation type

Specific requirements differ depending on the transportation type (for requirements for North America, [see section 3.1.1](#)).

Land and air freight

- ▶ Preferred external dimensions: L1200 x W800 x H1000 mm
- ▶ For air freight, the use of sea freight pallets is also permitted.

Sea freight

Due to long transportation distances and times, and changing requirements (climatic zones, mechanical stress, moisture, etc.), special attention must be paid to suitable packaging for sea freight.

- ▶ Preferred external dimensions for optimum utilization of shipping container loading volume:
 - L1140 x W790 x H460/750/1045 mm
 - L1140 x W980 x H460/750/1045 mm
- ▶ Use of outer cartons with moisture-proof / waterproof adhesive.
- ▶ Small cartons (<400 x 300 mm) are to be combined and protected using a completely filled (for stackability) larger external carton.
- ▶ The loading volume of the shipping container must be completely utilized. The SUPPLIER must ensure dynamic stackability to achieve this (normally 2-3 layers). A safety factor is to be calculated using the following formula.

$$\text{Sicherheitsfaktor} = \text{Belastbarkeit} \frac{\text{(ermittelte Bruchlast im Normklima)}}{\text{geforderte zulässige Auflast}}$$

Based on the VDA recommendation 4525, the SUPPLIER must adhere to a safety factor of ≥ 3.5 (breaking strength of loading unit determined in a standardized climate).

According to the VDA recommendation 4525, different packaging systems can be used for sea freight.

- Nominal dimension modular series B1: Max. external dimensions, max. useful volume, internal dimensions \geq plastic small load carrier (abbr.: SLC) internal dimension, large load carrier (abbr.: LLC) usable without external ring

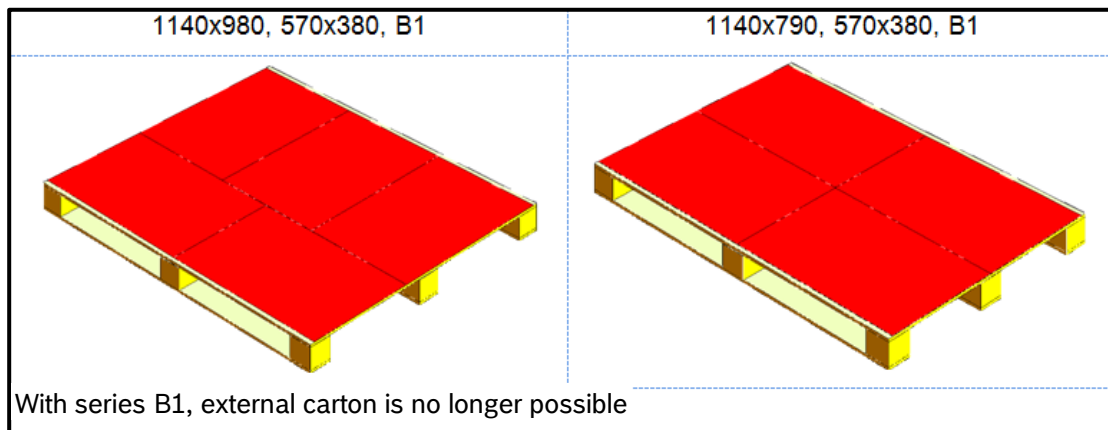

Figure 2: Series B1 for deliveries without external carton

- Nominal dimension modular series B3: External dimension \leq plastic small load carrier internal dimension, use of outer ring LLC

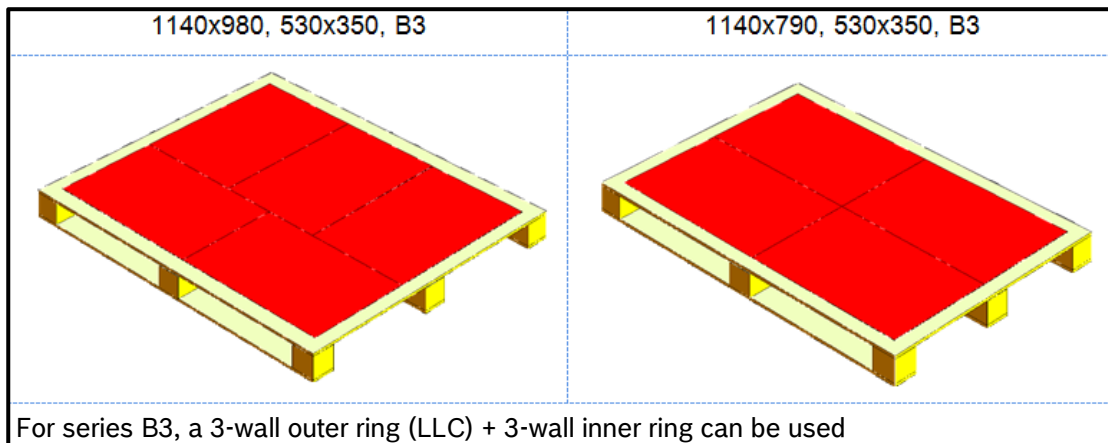

Figure 3: Series B3 for deliveries without external carton

3.3 Returnable packaging

3.3.1 Specification depending on type of returnable packaging

Euro pallet or Euro pallet cage

An exchange process (exchange full containers for empties) is to be used for preference and therefore for empties accounting directly between BOSCH and the SUPPLIER. If the supply of Euro pallets / Euro pallet cages involves an exchange process with LSPs (European Pallet Association e.V; quality criteria: Internet: www.epal-pallets.org), the SUPPLIER is responsible for the exchange process.

BOSCH-returnable empties

BOSCH-returnable empties include standard and special load carriers. These are procured by BOSCH and remain the property of BOSCH. The returnable packaging is specified by BOSCH based on internal standards. Proposals from the SUPPLIER for the design of returnable packaging are welcome. The SUPPLIER is responsible for the product quality.

BOSCH covers the requirement for empties for the transportation time in both directions.

Unless agreed otherwise, the SUPPLIER will receive BOSCH-returnable empties for a product inventory of three (3) days without BOSCH charging the SUPPLIER a usage fee for this. For use of BOSCH-returnable empties exceeding the

aforementioned inventory of three days, BOSCH can charge the SUPPLIER a usage fee. The usage fee is calculated based on the inventory data of the empties accounts in the empties management system (see [section 3.3.2](#) and [Chapter 7](#)).

If the SUPPLIER uses fewer BOSCH-returnable empties than described/agreed above, there is no remuneration by BOSCH.

Unless otherwise agreed, the SUPPLIER may, after prior approval by the BOSCH contact, provide BOSCH-returnable empties to their sub-suppliers for the BOSCH-specific production processes. In the production process for BOSCH-returnable empties used by the subcontractor, the empties account of the SUPPLIER is credited and, if necessary, also debited the SUPPLIER in accordance with the regulation described above. The SUPPLIER is liable to BOSCH for damage caused by the SUPPLIER or their sub-suppliers to the BOSCH-returnable empties. The SUPPLIER must cover a fault of their subcontractor to the same extent as they do their own.

Supplier-specific special load carriers

The SUPPLIER may only use supplier-specific special load carriers in exceptional cases that have been agreed on with BOSCH. This requires a written agreement between SUPPLIER and BOSCH. The SUPPLIER is responsible for performing construction and procurement. Costs and repairs, responsibility for load securing, and on-time provision are borne by the SUPPLIER.

3.3.2 Empties management

For the purpose of empties management, the SUPPLIER will indicate the ten-digit BOSCH packing material number and corresponding quantity on the delivery note for every delivery (see [section 4.2.1](#)).

If exchange pallets are used, these must also be listed on the delivery note.

The SUPPLIER and BOSCH - or an LSP engaged by BOSCH - keep empties accounts and reconcile the account balances with their direct exchange partner. The SUPPLIER will use the empties management system stipulated by BOSCH.

The account balances are provided to the SUPPLIER monthly. Any complaints must be received by the BOSCH contact within 14 calendar days with submission of a document copy (delivery note). Otherwise, the stated inventory is considered to be confirmed by the SUPPLIER. Quantity differences must be clarified by the SUPPLIER with support from the BOSCH contact or the LSP. Any outstanding quantity differences are to be reconciled with the replacement value according to the causation principle.

The SUPPLIER will conduct stock taking for all BOSCH-returnable packaging every year on a date specified by BOSCH. Within the framework of the quantity differences established during inventory, the SUPPLIER must reconcile with the replacement value.

3.3.3 Provision and storage of BOSCH-returnable empties

Where a 1:1 (without time delay) exchange of full containers for empties between BOSCH and the SUPPLIER is agreed, the SUPPLIER must request BOSCH-returnable empties in good time (taking into account the lead times agreed with the exchange partner) using the designated empties management system.

In Europe, Turkey, and Russia, BOSCH returnable empties are supplied free of charge to the agreed unloading point. Where differing procedures are in place in other regions, this must be agreed in writing.

The SUPPLIER will check the returnable empties on receipt and report any defects identified (e.g. quantity differences, damage) immediately to the BOSCH contact, specifying the delivery note, photographic evidence, and a short description of the complaint. The subsequent procedure is to be agreed with the BOSCH contact in the individual case.

The SUPPLIER must store returnable empties in such a way that contamination before, during, and after the production process is ruled out.

3.3.4 Repairs and scrapping

Bosch-specific load carriers may only be scrapped or repaired by the SUPPLIER after approval from BOSCH.

3.3.5 Cleaning

Cleaning responsibility differs by region due to the defined standards:

Deliveries BOSCH - SUPPLIER	Cleaning responsibility	Alternatives
Within Europe, Turkey and Russia,)	BOSCH	With corresponding profitability analysis or urgent necessity, e.g. quality requirements
Within NAFTA	SUPPLIER	With corresponding profitability analysis or urgent necessity, e.g. quality requirements. When new supply relationships are commenced, the contract may only be awarded after a profitability analysis has been conducted.
Within Latin America	By agreement	
Within Asia Pacific (including India, China, Japan, Association of Southeast Asian Nations (abbr.: ASEAN)	By agreement	
Within Africa	By agreement	
Across regions	SUPPLIER	No alternatives permitted

Figure 4: Cleaning Responsibility by region

As part of their quality responsibility, the SUPPLIER will pack their products only in packaging that meets the cleanliness requirements for their products and the BOSCH specifications.

If subsequent cleaning of empties is necessary when BOSCH has the cleaning responsibility, possible payment of costs by BOSCH is to be agreed with BOSCH in advance. The SUPPLIER must provide evidence of the contamination caused by BOSCH.

3.3.6 Labeling of BOSCH-returnable packaging by the SUPPLIER

No labels, signs or similar items may be stuck to BOSCH returnable load carriers. The standard label holders attached are to be used for labeling the load carriers. The product tag is inserted in the label holder and, if necessary, secured with a maximum of two easy to detach adhesive points (complying with VDA recommendation 4500/4504).

3.3.7 BOSCH standards for returnable SLC

BOSCH aims to introduce standardized packaging systems across the company. For production parts, BOSCH uses VDA Redesign Light (abbr.: RL)-SLC according to the VDA recommendation 4500/4504. In individual cases, the Classic (abbr.: C)-SLC is used.

3.3.8 Adapter pallets and roller carriages

From the perspective of the BOSCH production system (abbr.: BPS), an integrated concept is required in a production plant with rolling transport units (flexible handling, forklift-free production, etc.). If sufficiently efficient, this concept can also be used directly by the SUPPLIER to avoid repacking processes at BOSCH (VDA SLC on pallets from SUPPLIER → VDA SLC on stacker for BOSCH). The transport safety of the rolling stacker is guaranteed by the adapter pallet.

Two sizes of floor rollers can be used, although the roller with the dimensions 600x400 mm is preferred. Alternatively, a roller with the dimensions 400x400 can be used.



Figure 6: Example adapter pallet



Figure 5: Example roller carriage type | 600x400mm

Inner packaging (one-way or returnable packaging)

To protect the products and make handling easier, for some packaging, inner packaging is also required. This can be returnable (e.g. thermoformed moldings) or made of one-way materials (e.g. corrugated cardboard inserts). The requirement for inner packaging is derived from economic and qualitative considerations and is agreed between SUPPLIER and BOSCH.

The requirements for one-way packaging ([see section 3.2](#)) and returnable packaging ([see section 3.3](#)) also apply to inner packaging.

4 Transport logistics

The aim is punctual, complete, perfect quality, and access secure delivery to BOSCH by the SUPPLIER.

4.1 Basic information on shipping from SUPPLIER to BOSCH

4.1.1 Transportation companies, couriers, and package shipments

If BOSCH is paying for the freight, the SUPPLIER shall use only the forwarders / freight carriers, and courier companies (LSP) specified by BOSCH. Exceptions are only permitted in justified cases and after prior written approval by the BOSCH contact.

For transport processed through a BOSCH Transport Management Center (abbr.: TMC) and the BOSCH Transport Management System (abbr.: TMS), the SUPPLIER reports the transport requirements (number of packages, dimensions, weight) to the TMC, which selects and engages the LSP for BOSCH.

Packages with a weight of up to 31.5 kg and a size within the maximum combined length and girth (as defined in [Chapter 9](#)) are processed using the specified courier companies. The regulations for packaging selection must be complied with ([see section 3.1.2](#)). The SUPPLIER must observe any differing regional guidelines for packages and package shipments. Multiple deliveries to the same BOSCH unloading point on a single day are to be combined by the SUPPLIER into a logistically sensible shipping unit and processed using the specified LSP.

4.1.2 Packages and HUs

Packages / HUs must be delivered unmixed (e.g. separated by batch, revision, part number ([see section 3.1.1](#) and [section 3.1.4](#))). The agreed packaging specification is applicable, and also sets out possible alternative packaging.

Before using mixed HUs, the SUPPLIER must get the approval of the BOSCH plant supplied. Mixed containers must be clearly marked as such by the SUPPLIER. Different revisions of the same product may never be combined in a single packing unit or a package / HU.

The SUPPLIER must agree delivery of remaining quantities in incomplete containers with the BOSCH contact and clearly mark them after consultation.

4.2 Shipping and transportation documents

Shipping documents accompany the products, while transportation documents can include several deliveries and are assigned to the shipment.

4.2.1 Shipping documents

The SUPPLIER creates the shipping documents preferred by BOSCH, based on the VDA or Automotive Industry Action Group (abbr.: AIAG) standards. Regional standards can be taken from the following table:

REGION	STANDARD
Europe	VDA, Odette
North America	AIAG
South America	<i>Rede Nacional de Dados</i> (abbr.: RND (ASN) and VDA, Odette (delivery documents / label))
South Africa	VDA
Australia	Electronic Data Interchange For Administration, Commerce and Transport (abbr.: EDIFACT); Global Standard One (abbr.: GS1 (as defined under Chapter 9))
Asia	VDA preferred standards are to be agreed with the BOSCH plant supplied.
- Japan	SUPPLIER with SupplyOn link: "Delivery Note" printout from SupplyOn SUPPLIER without SupplyOn link: "Order Sheet" (provided by the BOSCH plant supplied)

Figure 7: Regional standards for shipping documents

Delivery note

The delivery note issued by the SUPPLIER must contain at least the following information:

- ▶ SUPPLIER name and sender address
- ▶ SUPPLIER number assigned in relevant BOSCH plant supplied
- ▶ Recipient address (plant supplied, unloading point as per call-off, for example)
- ▶ BOSCH part number (abbr.: pn).
- ▶ Total quantity of pn
- ▶ Number & type of packaging with ten-digit BOSCH packing material number (e.g. SLC, Colli, Euro pallets)
- ▶ Number of exchange pallets used per order (see also [section 3.3.3](#))
- ▶ Delivery note number also printed as a barcode on the delivery note, format in code 39 as specified by the International Standards Organization (abbr.: ISO) / International Electrotechnical Commission (abbr.: IEC) 16388.
- ▶ BOSCH order number or call-off number including line.
- ▶ Batch number and, if necessary, shelf life expiration date (abbr.: SLED).
- ▶ Parts list revision or if revision is not used: Parts list change number.
- ▶ For consignment stock, the following wording is noted: "For CONSIGNMENT STOCK only".
- ▶ Mixed HUs: (See [section 4.1.2](#) and [section 3.1.1](#).)

Division or plant-specific specifications are to be observed.

4.2.2 Transport documents

In addition to the shipping documents, to record the shipments the SUPPLIER normally provides the LSP with the following information: Transport documents and customs documents.

Transport documents

Standard transport / forwarder order, e.g. VDA 4922, waybill

For shipments processed through the BOSCH TMC and BOSCH TMS, the SUPPLIER creates the waybill directly from the TMS. As a result, the Transport Order (abbr.: TO) number is adopted automatically to the waybill.

Customs documents

The SUPPLIER provides the LSP with all documents necessary for customs clearance, i.e. for export in the country of origin, for transit if applicable, and for import in the destination country, in a permitted form (electronic or in paper form - copies or originals, signed or not signed) and at the correct time.

Typical customs clearance documents include:

- ▶ Export declaration.
- ▶ Commercial invoice (or in the case of consignment deliveries or non-chargeable samples, a pro-forma invoice).
- ▶ Packing list.
- ▶ Packing declaration.
- ▶ Certificate of non-preferential origin or proof of preferential origin (included in the applicable free trade agreement).

The regional forms and resulting details are to be agreed with the BOSCH plant supplied.

4.3 Labeling of products

HUs/packages are to be labeled with a main product tag (master label) by the SUPPLIER.

For shipments processed through the BOSCH TMC and BOSCH TMS, the SUPPLIER is responsible to establish a clear assignment between main product tag and TO. In coordination with the TMC, the SUPPLIER can opt for one of the following variants:

- ▶ The TO number is applied in addition to any main label with a TO label, which is printed in TMS. ([See Appendix 2: TO: Transport Order](#)).
- ▶ The obligation to attach the TO label shall not apply if the SUPPLIER enters the delivery note number in a machine-readable format in the TMS-TO, and uses a material (abbr.: MAT) label that contains the delivery note number.

The smallest **packing units** are to be labeled with a secondary product tag (label) by the SUPPLIER. The secondary product tags must be provided with a barcode label / Radio Frequency Identification (abbr.: RFID) tag ([see Chapter 7](#)).

The main and secondary product tags are to be attached to the outside of the packing units in a clearly visible position. The label pockets provided are to be used.

Product tags on returnable packaging must be easily detachable with no residue and there may not be any additional cleaning work required.

The content of the label must comply with [section 4.2.1](#). Unless otherwise agreed, the preference for labeling of goods is the Global Transport Label (abbr.: GTL) from the international organizations AIAG, Odette, or VDA. In addition, unless otherwise agreed, the label on a package / HUs must include a unique identifier (abbr.: ID) (created in compliance with a current standard such as VDA/ISO or GS1 - [see Further developments in logistics, Chapter 7](#)).

Unless otherwise agreed in writing with the corresponding responsible BOSCH contact, a MAT label (VDA4992 or BOSCH) must be used for the divisions Automotive Electronics (abbr.: AE) and Car Multimedia (abbr.: CM). When using the MAT label, the specific requirements specified in the Purchasing & Logistics download area must be complied with. Internet: www.bosch.com > Purchasing & Logistics > Downloads > Logistics > MAT label.

Format and attachment

REGION	STANDARD
Europe	The main product tag for the shipping unit must be in DIN A5 landscape format. The secondary product tag must be in the format 210 x 74 mm (VDA standard). The attachments provided on the SLC are to be used. Adhesive labels are prohibited.
North America	AIAG
South America	Standard Label Odette; VDA e.g.: for Automotive Aftermarket (abbr.: AA) for export to Germany
South Africa	Standard VDA label
Australia	EDIFACT, GS1
Asia	VDA preferred, standards are to be agreed with the BOSCH plant supplied.
- Japan	SUPPLIER with SupplyOn link: "GTL label" printout from SupplyOn SUPPLIER without SupplyOn link: "4 part form" (provided by BOSCH plant supplied)

Figure 8: Format and attachment of product tags

Examples can be found in [Appendix 3: Label](#).

Unless otherwise agreed, all barcodes are to be created in code 39 in line with ISO/IEC 16388.

For KANBAN processing between BOSCH and the SUPPLIER, the SUPPLIER must attach KANBAN cards in a clearly visible position on the defined packing unit, in line with the agreement with the BOSCH plant supplied. The KANBAN cards are provided by BOSCH.

4.4 Transport notification

4.4.1 Transports not processed through BOSCH TMC

If the shipment is not processed via the BOSCH TMC, then the SUPPLIER issues a notification to the LSP specified by BOSCH (cf. [section 4.1.1](#)). This is done independently and according to the requirements of the LSP to ensure on-time delivery to BOSCH. Exceptions are only permitted after prior written approval by the BOSCH contact.

Collection by the LSP takes place within a defined time window or at the time individually agreed between the SUPPLIER and LSP.

4.4.2 Transports processed through BOSCH TMC

If the transport is handled by the Bosch TMC, a direct notification of the LSP, as described in [section 4.4.1](#), is no longer permissible. The SUPPLIER issues a notification for each transport requirement to the BOSCH TMC in line with the applicable regulations for order acceptance, processing times, and cutoff times (as defined in [Chapter 9](#)). The SUPPLIER enters the transport requirement in the BOSCH TMS in the form of a TO ([see Appendix 2: TO: Transport Order](#)).

A TO is created in TMS in one of the three following ways:

- ▶ SUPPLIER creates the TO manually.
- ▶ System side creation on each shipping date based on the saved route.
- ▶ System side creation on each shipping date based on the material call-off from the BOSCH plant supplied.

In all three cases, the TO must contain the following information, which is either pre-entered by the system or manually entered by the SUPPLIER depending on the TO creation method.

- ▶ Sender and recipient data.
- ▶ Shipment data: Type and number of packages/HUs, gross weight, dimensions, stacking factor.
- ▶ Order data: Order number, delivery note number.
- ▶ Item data: Part number, quantity.

The SUPPLIER checks the above data and confirms it by saving. Saved TOs are binding once the cutoff time for this shipment has passed. If, after the cutoff time, quantity variances arise between the transport notification and the actual transport needs, they should be entered directly into the TO not later than on the day of the pick-up. If the additional requirement exceeds the maximum loading capacity, the BOSCH TMC must be informed immediately by phone or mail.

4.4.3 Special arrangements for transportation of critical goods

The SUPPLIER issues separate notifications for transport-critical shipments.

For **hazardous goods**, the SUPPLIER is responsible for ensuring that the collecting LSP is provided with all the required hazardous goods documents in advance, and that they are complete and correct.

Critical material property

The LSP must be notified of products that cannot be packaged because of their nature and extremely bulky products before shipment, as well as the required temperature control for heat or frost sensitive materials.

High-value goods, e.g. gold wire, are to be transported with security precautions appropriate to their value.

4.5 Label for sample parts

Sample parts are to be sent exclusively to the delivery address specified in the order. In addition, sample parts must be clearly labeled as such on the outer packaging. How they are to be labeled is to be agreed with the BOSCH contact in advance. Sample deliveries may never be delivered together with a series delivery (pallet, pallet cage, etc.), but must be delivered in separate packing units.

4.6 ASN

For each shipment, the SUPPLIER will send an ASN to BOSCH using EDI at the same time as the products are picked up by the LSP. The information in the ASN must match that on the delivery note.

For new connections, the transfer protocol Odette file transfer protocol (abbr.: OFTP2) and Applicability Statement 2 (abbr.: AS2) must be used, as well as message format ODETTE GLOBAL EDIFACT. Which fields within the ASN are defined individually as mandatory or optional fields and to be communicated accordingly by the SUPPLIER, can be determined from the document "Message Implementation Guideline: GLOBAL DESADV", which can be downloaded from the EDI Bosch Portal at www.edi-service.bosch.com.

For previous processing using the standard VDA label, VDA4913 is the preference. This usage is based on the agreements made in the VDA working group "Templates/data exchange" ("*Vordruckwesen / Datenaustausch*"). These specify standardized sentence structures (fixed length of 128 characters) and standardized data elements, field lengths, field types, keys/codes, to be used as a binding programming basis for remote data transmission parties. It must be ensured that the data in the VDA 4913 message and the data on the shipping and transportation documents (e.g. shipping order, delivery notes or product tags, etc.) correspond ([see section 4.2](#)).

The corresponding procedure can be found in the VDA standard 4913.

4.7 Shipping process

When collecting the goods, the LSP acknowledges the number and type of packages or shipping units collected, but not their content, value, or weight. During transportation, the LSP must convey all shipping documents separately from the material itself.

4.8 Security in goods transportation

The SUPPLIER must provide the products securely for loading as air freight, in line with the applicable legal requirements and directives (e.g.: EU VO 300/2008), i.e. in such a way that they can be transported as air freight without any additional work for BOSCH (X-rays, sniffer dogs, or other checks) and with no delays. For example, in Europe this can be done by achieving certification as a known sender or by having the products secured by an authorized agent. If the SUPPLIER arranges transportation of the products to the airport, a LSP certified as an authorized agent or a certified transporter is to be chosen in order to ensure a secure supply chain. A written declaration of the security status on the shipping documents is required for air freight, and is also recommended for other transportation methods.

For goods shipments listed below, the regulations for the USA must also be observed:

- ▶ Into the USA
- ▶ Products with a US origin
- ▶ Products that consist partly of US products
- ▶ Products developed and/or produced with US expertise
- ▶ Products developed and/or produced using US financing

The Customs-Trade Partnership Against Terrorism (abbr.: C-TPAT) regulations "C-TPAT Minimum Security Criteria and Guideline" issued by U.S. Customs and Border Protection must be observed and can be downloaded from www.cbp.gov.

On request, information relevant for C-TPAT is to be provided to the BOSCH contact.

5 Special transports and variation management

5.1 Special transports

Special transports are organized by SUPPLIER after prior consent from the BOSCH contact. Special transports are made if there is a need to deviate from the defined standard transport method and processing due to process faults, in order to reduce transport times.

The SUPPLIER informs the responsible BOSCH contact of the transport details.

The costs for special transports are borne by the party responsible for the process disturbance, in line with the causation principle.

For costs to be assumed by BOSCH, a written declaration of acceptance of costs must be provided by BOSCH.

Every special transport caused by the SUPPLIER is recorded by BOSCH and is incorporated into the SUPPLIER assessment.

5.2 Variation management

The SUPPLIER must provide evidence of a defined process for early warning and escalation management for the occurrence of process variations, in compliance with ISO 9001/ISO TS 16949.

The early warning system of the SUPPLIER for prompt detection of potential delivery bottlenecks must be based on the required replenishment times for products.

If failures occur for SUPPLIER that have an impact on the deliveries to BOSCH, (especially delivery date or quantity, quality) the SUPPLIER must take the required measures to resolve the failure, taking into account the BOSCH quality requirements.

If it is identifiable that - in spite of the measures taken - agreements or assurances cannot be met, the SUPPLIER must immediately notify the BOSCH contact of this without being requested to do so. The SUPPLIER must agree the further procedure, e.g. regarding new delivery date or a new delivery quantity with BOSCH.

If requested by BOSCH, the SUPPLIER must notify BOSCH of at least the following points:

- ▶ Cause of the disruption.
- ▶ Maximum production capacity, planned / actual output quantities, personnel capacity, and the current shift model (hours, number of shifts, and working days per week). Tracking sheets specified by BOSCH must be completed truthfully and on a rolling basis with current figures and data, and transferred to BOSCH.
- ▶ Reviewed alternative production options, including any risks.
- ▶ Deliverable alternative parts.
- ▶ Options for lot splitting and partial deliveries.
- ▶ Options for reducing the transportation time using special transports.
- ▶ Backlog reduction plan.
- ▶ Process analysis / bottleneck process analysis.

Any consequential costs of disturbances caused by the SUPPLIER are borne by the SUPPLIER in line with the causation principle. Any other claims by BOSCH from or in connection with special shipments, process deviations, non-compliance with delivery dates or quantities, as well as other disturbances remain unaffected.

5.3 Risk and crisis management in logistics

5.3.1 Background

Many events require activities or measures that are not covered by the standard processes and resources in place. Therefore, customers increasingly require professional risk and crisis management solutions from BOSCH. To ensure BOSCH's delivery capability, a professional approach to risks and crises is required on the SUPPLIER side (as defined in [Chapter 9](#)).

5.3.2 Definition, tasks, and objectives

BOSCH defines risk management in logistics as proactive stabilization of the supply chain. This includes, among other things, provision of proactive, event-based, prompt, and ongoing information on the current supply status, and safeguards in the supply chain and by the SUPPLIER (stock coverage, date for restarting production, date for production). Based on a risk analysis, the SUPPLIER must develop and implement appropriate strategies that reduce the susceptibility of the supply chain and guarantee a continuous supply to BOSCH (even in a crisis).

Crisis management involves prevention of and systematic response to crises in the supply chain. The objective is to neutralize or minimize the impact of crises using appropriate measures.

The SUPPLIER provides structured, proactive, and ongoing communication.

This includes a realistic situation assessment in terms of potential risks, which could impair delivery capability to BOSCH (time, quantity, quality at material level) as a crisis advances.

After a request from BOSCH, the SUPPLIER will set out their planned, current, and completed measures and results.

Possible internal and external incidents and causes of crises:

- ▶ Fire or water damage.
- ▶ Disturbance of necessary transportation infrastructure.
- ▶ Natural disasters (e.g. earthquake, tsunami, volcanic eruption, hurricane).
- ▶ Political events (e.g. social unrest, financial / currency crises).
- ▶ Strikes (e.g. by forwarder).
- ▶ Epidemics (restricting production or transport capability).
- ▶ Crime and terrorism.
- ▶ War and conflict.

6 Logistics quality

6.1 Definition

Avoidance of process failures in logistics over the entire supply chain from the SUPPLIER to the customer is increasingly important for BOSCH. Therefore, SUPPLIER has to comply with the applicable requirements in relation to delivery and logistics. Costs, which occur to BOSCH as a result of deviations to valid requirements or as a result of other logistics failures can be charged to the SUPPLIER who caused them ([see section 6.2.](#)).

6.2 Logistics complaints

A logistics complaint can be triggered by a failure in processes at BOSCH that was caused by the SUPPLIER.

Logistics complaints are recorded and evaluated internally by BOSCH in terms of the costs caused in this context.

The SUPPLIER shall be liable for costs arising from logistics errors and/or damages in line with the causation principle.

In the event of failure to comply with the specifications set out in this supplier manual, and any additional requirements defined for a specific location, BOSCH reserves the right to refuse to accept the shipment.

The SUPPLIER is notified of a logistics complaint and is requested to analyze the failure pattern or the logistics failures and implement appropriate measures. The logistics complaint from BOSCH is to be processed and documented by the SUPPLIER in line with the 8D system. BOSCH can request the documentation.

For specific suppliers, a logistics self-assessment including planned measures (for example based on Global Materials Management Operations Guidelines / Logistic Evaluations (abbr.: MMOG/LE) (as defined in [Chapter 9](#))) can be demanded. BOSCH also reserves the right to assess the supply chain maturity at the SUPPLIER site or to conduct process audits on the SUPPLIER with the active participation of the SUPPLIER.

The regulations on warranty claims, product liability, callbacks, as well as cancellation and termination rights in paragraphs 9 to 11 of the Robert Bosch GmbH terms and conditions of purchase (as of 11/2015) shall apply in the event of logistics-related failures. Other claims by BOSCH in connection with logistics complaints remain unaffected.

6.3 SUPPLIER Result Assessment (abbr.: LEB) – Logistics

The aim of the LEB is a comprehensive systematic assessment of SUPPLIER based on standardized criteria. The results of the LEB form the basis for Dynamic Supplier Classification (abbr.: DSC) as well as for SUPPLIER development measures.

As part of the LEB, the LOG-LEB monitors selected logistics criteria for each BOSCH plant supplied in the assessment period:

- ▶ Logistics failures
Recording of variations, e.g. for labels, markings, quantity.
- ▶ Delivery reliability / performance (on time delivery (abbr.: OTD))
Assessment of compliance with min/max inventory limits when using VMI or compliance with delivery dates and quantities for call-offs.
- ▶ Communication, cooperation, flexibility
Assessment, e.g. of cooperation or availability.
- ▶ Special transports
- ▶ Special topics such as e.g. EDI, ASN.
- ▶ Logistics self-assessment.

The responsible BOSCH contact can provide information about details of the plant-specific logistics results from the LOG-LEB.

6.4 Controlling of logistics performance by SUPPLIER

The SUPPLIER will monitor the performance indicators set out below to determine their logistics performance, and will provide BOSCH with the results and relevant documentation on request.

Delivery reliability / performance

The SUPPLIER has a system for monitoring and measuring their delivery performance (date, quantity) based on the order data from the BOSCH plant supplied. Measurement and recording must be carried out at least monthly.

Special transports

The SUPPLIER will maintain monthly records of all special transports made to BOSCH (number, date, affected part numbers, cause).

Logistics quality

The SUPPLIER will internally monitor their logistics quality. Monitoring must include complaints from receiving locations in the supply chain (e.g. BOSCH plant supplied, forwarder, warehouse, BOSCH customer). In addition, the SUPPLIER must maintain a complaint management system for delivering locations and monitor these complaints.

For all named key figures, an effective deviation management must exist (e.g. plan-do-check-act (abbr.: PDCA)) with the aim of improving the involved logistics processes and their key figures.

7 Further developments in logistics

BOSCH is continuously making further efforts to improve its incoming and outgoing logistics processes. This will lead to changing requirements for the SUPPLIER in the future. The fundamental objective is standardization and reduction to a small number of logistics concepts, and thus to define uniform global requirements and standards.

The focus is currently on:

- ▶ Ensuring the SUPPLIER's **e-business capability** and further expanding **digitalization of the supply chain**, with the introduction and establishment of control and transport concepts (e.g. TMC/TMS, inbound concept for EZRS parts, etc.)
- ▶ Standardized global implementation of the **GTL**
- ▶ Implementation of measures to simplify empties processes, such as introduction of alternative **empties management concepts**, e.g. purchase/buy back or RFID for tracking empties.
- ▶ Further rules for the **empties management** (see section 3.3.1) can be found in the brochure "*Empties Fee Settlement*" from mid-2017 at www.bosch.com (in the Purchasing & Logistics download area).
- ▶ In future, specified dates for deliveries will correspond to **dispatch dates** (shipping dates) by the SUPPLIER.
- ▶ Adaptation of supply chains to new trends and developments, e.g. with the use of RFID or developments as part of **Industry 4.0**:

RFID:

If RFID is used, the SUPPLIER must be able to process and bring into circulation RFID labels based on VDA recommendations 5500/5501. In bilateral communication with BOSCH, the preference is to use Electronic Product Code (abbr.: EPC) labeling based on GS1. If the SUPPLIER brings returnable packaging into circulation, other standardized data structures can be used as an alternative (e.g. ISO/IEC).

Relevant VDA recommendations:

- VDA 5510 - RFID for parts tracking V2.0 April 2015
- VDA 5500 - Principles of RFID use in the automotive industry Version 1.2
- VDA 5501 - RFID use in container management V2.0 April 2015
- 5509 AutoID/RFID use and data transfer for tracking of parts and components in vehicle development.

Electronic Product Code Information Service (abbr.: EPCIS):

In future, the SUPPLIER must be able to uniquely identify objects (products, shipping units, etc.) and to create messages regarding these objects as EPCIS events complying with the specifications in the current EPCIS standard (see ISO/IEC 19987) and send these to BOSCH. The object identification schemes used must be unique and created in compliance with an applicable standard such as GS1 or VDA/ISO).

The EPCIS events to be communicated include at least:

- Goods dispatch.
- Object identification of the shipping unit (e.g. Serial Shipping Container Code (abbr.: SSCC (as defined in Chapter 9)), see also section 4.3).
- The location (Global Location Number (abbr.: GLN) or GLN with or without additional extension (abbr.: SGLN)).
- A time stamp.
- Business steps according to Core Business Vocabulary (abbr.: CBV)/ Automotive Business Vocabulary (abbr.: ABV).
- Also: Material number, reference to ASN, TO, delivery note, call-off number.
- Internal production and packaging steps.
- Object identification of the material or the packing unit (e.g. Global Trade Item Number (abbr.: GTIN) or Serialized GTIN (abbr.: SGTIN)).
- Also: Product parameters (e.g. eMatLabel from production VDA 4992).

Other EPCIS events will be defined bilaterally as required. For further information, refer to the GS1 documentation (EPCIS standard, CBV, ABV, guidelines, etc.).

- Global traceability: Quality data is transferred to BOSCH.
- TraQ (Tracking and Quality): returnable containers (SLCs) fitted with sensors to be brought into circulation.

The SUPPLIER agrees to the proactive participation of the above development, if necessary, in collaboration with LSP. Only SUPPLIERS who are willing to work with BOSCH to move over to new, cooperative logistics concepts can expect a long-term business relationship with BOSCH.

8 Index of abbreviations

AA	Automotive Aftermarket (division of BOSCH)
ABS	Acrylonitrile-butadiene-styrene
ABV	Automotive Business Vocabulary
ABx	Management purchasing material field x
AE	Automotive Electronics (division of BOSCH)
AIAG	Automotive Industry Action Group
ANFAVEA	Associação Nacional dos Fabricantes de Veículos Automotores
ASEAN	Association of Southeast Asian Nations)
ASN	Advanced Shipping Notification
AS2	Applicability Statement 2
BBM	Mobility Solutions business unit
BPS	Bosch Production System
CBV	Core Business Vocabulary
C-SLC	Classic SLC
CM	Car Multimedia (division of BOSCH)
C-TPAT	Customs-Trade Partnership Against Terrorism
D.C.	Deconsolidation Center
DIN	German Institute for Standardization e. V. (<i>Deutsches Institut für Normung e.V.</i>)
DSC	Dynamic Supplier Classification
EDI	Electronic Data Interchange
EDIFACT	Electronic Data Interchange For Administration, Commerce and Transport
EPC	Electronic Product Code
EPCIS	Electronic Product Code Information Service
EPE	Expanded polyethylene
EPP	Expanded polypropylene
EPS	Expandable polystyrene
ERP	Enterprise Resource Planning
ESD	Electrostatic Discharge
ESDS	Electrostatic Discharge Sensitive Device
EZRS	Products and raw materials
GLN	Global Location Number
GTIN	Global Trade Item Number
GTL	Global Transport Label
GS1	Global Standard One
HAWA	Merchandise Products (<i>Handelsware</i>)
HIBE	Operating Supplies (<i>Hilfs- und Betriebsstoffe</i>)
HU	Handling Unit
ID	Identifier, indicator
IEC	International Electrotechnical Commission
IPPC	International Plant Protection Convention
ISO	International Standardization Organization
ISPM	International Standards for Phytosanitary Measures
JIT call	E-Kanban
LEB	SUPPLIER Result Assessment (<i>Lieferantenergebnisbewertung</i>)
LLC	Large load carrier
LSP	Logistics Service Provider
MAT	Material
MAZE	Machine accessories and replacement parts (<i>Maschinenzubehör- und Ersatzteile</i>)

MYC	(Multi Year Contract)
MMOG/LE	Materials Management Operations Guidelines/Logistics Evaluation
NAFTA	(North American Free Trade Agreement)
OFTP2	Odette File Transfer Protocol 2
OTD	On time delivery
PDCA	Plan Do Check Act
PE	Polyethylene
PET	Polyethylene terephthalate
PN	Part number
PO	Purchase order
PP	Polypropylene
PS	Polystyrene
PT	Power Tools (division of BOSCH)
PUR	Polyurethane
PVC	Polyvinyl chloride
RESY	Recycling symbol
RFID	Radio Frequency Identification
RL-SLC	Redesign light SLC
RND	Rede Nacional de Dados (ANFAVEA)
ROP	Reorder Point
SBI	Self billing invoice
SGLN	GLN with or without additional extension
SGTIN	Serialized Global Trade Item Number
SLC	Small load carrier
SLED	Shelf life expiration date
SSCC	Serial Shipping Container Code
STL	Ship to line
TCO	Total Cost of Ownership
TMC/TMS	Transport Management Center/System
TO	Transport Order
VATIN	Value added tax identification number
VCI	Volatile Corrosion Inhibitor
VDA	German association of the automotive industry (<i>Verband der Automobilindustrie</i>)
VMI	Vendor Managed Inventory

Figure 9: Index of abbreviations

9 Definition of terms

Alternative packaging	An alternative to the packaging agreed for the series delivery (normally consisting of one-way materials). Alternative packaging is normally to be added to the packaging specification.
BOSCH contact	The contact named by BOSCH for the SUPPLIER (usually the procurement planner of the BOSCH plant supplied)
BOSCH plant supplied	This term includes D.C. in the event of HAWA or consignment goods.
Call-off	BOSCH creates schedule lines with quantities and delivery dates and transmits these via call-offs to the SUPPLIER. The call-off consists of (in addition to the non-binding preview) the order of the products to be supplied by the SUPPLIER on the delivery date specified in the call-off, and is adapted to the current requirements situation at BOSCH on a rolling basis.
Combined length and girth	Measurement (circumference [the two shorter sides] + longest side)
Composite materials	Material made of two or more combined materials (example: aluminum laminated bags, climate protection bags)

Crisis	Triggered by a temporary event situation that endangers or adversely affects the regular business of BOSCH, usually with possible adverse effects on the BOSCH customers.
Cutoff time	The cutoff time in the TMS/TMC environment defines the time by which the shipment and all relevant data must be registered (for collection to take place on the subsequent day). The standard cutoff time for release of the Transport Order (TO) is 11:00 on the day before collection.
Forecast requirements (preview)	Non-binding target figures outside the production release, according to which the SUPPLIER sets up their production capacities. They are only intended to provide information about the future needs of BOSCH to the SUPPLIER and to enable long-term planning capacity.
Global MMOG/LE	The <i>Global MMOG/LE</i> is a standardized assessment tool that contains around 200 logistics assessment criteria and measures an organization's processes against <i>best practice</i> in the industry. (Internet: www.odette.org/services/mmog)
Gross requirements (gross demands)	Gross requirements are the required BOSCH production requirements. Inventories in the BOSCH plant supplied or products that are on the way to production after withdrawal from the BOSCH warehouse are not included in gross requirements.
GS1 standard (SSCC code)	Refers to a globally unique ID. The SSCC (Serial Shipping Container Code) is used to uniquely identify logistical units (shipments, packages, HUs once).
Incoterm	The coding of an Incoterm comprises the following: XXX (e.g. FCA) and named place of delivery (e.g. FCA Zuffenhausen). The current Incoterms (e.g. current Incoterms 2010) shall apply.
Loading unit	Normally a pallet fully loaded with multiple packages.
Package	Multiple products combined into a carton or small load carrier.
Stacking factor (dynamic)	The stacking factor defines the number of identical parts / load carriers that can be stacked on top of one another. The dynamic stacking factor describes the same thing for moving quantities.
SUPPLIER	The contracting party of the applicable supply agreement on the vendor side
Working day	Working days in the SUPPLIER's country
Written / written form	Unless otherwise agreed, the requirement for written form is satisfied by a telecommunications communication of a declaration in a written message or using another method suitable for permanent reproduction in writing (e.g. e-mail or other electronic telecommunications systems).

Figure 10: Definition of terms

10 Appendices

10.1 Appendix 1: Delivery matrix: Central requirements for cooperation in logistics

No.	Procurement Control Concept	Incoterm	TAX	Customs	Payment	Data Exchange	Production- and material release	Flexibility rules	Minimum order qty
1.	KANBAN - Ship to Supermarket/STL (Ship to Line), from local supplier plant or from local supplier warehouse - if possible is the preferred concept	FCA "Place"	Not to be considered, unless it involves two different tax regions	Not to be considered, unless it involves two different customs regions	Payment according to transfer of ownership	Transfer Kanban JIT Call (short term) by means of SAP eKanban Transfer demand process / scheduling agreement release (mid/long term) via Classic EDI or Web-EDI --> Refer to the "Message Implementation Guideline: GLOBAL DESADV" Delivery of goods only in combination with codes (barcode/RFID tag) via label acc. to the GB / regional standard --> for further details see EDI-contract, KANBAN-contract and supplier manual logistics			
2.	VMI/Consignment - If KANBAN is not applicable, concept 2. VMI/Consignment is preferred	Standard: FCA "Place" Exceptions: DDP/DAP (for Electronics and for transport critical and dangerous goods)	According to local tax-, customs rules and legislation following options to be used (ranking): 1. Legal entity (supplier) 2. Free / Foreign Trade Zone (RB, LSP) 3. Bonded warehouse (RB, LSP) 4. Fiscal Agent (supplier) Regional specific consignment contract has to be used to define further details		(1) If legally possible: self-billing invoice SBI (GAV) (2) If SBI (GAV) is legally not possible: BOSCH provides withdrawal list ("Bewegungsliste")	Classic EDI or Web-EDI: - Transfer of VMI specific information - Advanced Shipping notification (ASN) (incl. - among others - packaging data) --> Refer to the "Message Implementation Guideline: GLOBAL DESADV" Labeling: Delivery of goods only in combination with codes (barcode/RFID tag) via label acc. to the GB / regional standard --> for further details see EDI-contract, VMI-contract and supplier manual logistics	Values to be defined individually, depending e.g. per materialfield, per supplier Default values: 4 weeks for production release, 8 weeks for material release	Short term requirements: supplier has to ensure an increase of up to +20% of the binding order (production release) compared with the last official forecast. Contract requirements: unless otherwise agreed, supplier has to ensure increase of orders up 33% based on the agreed quantity within (M)YC. ((Multi) Year Contract)	Minimum order quantity (MOQ) is prohibited, unless exceptions are approved by responsible ABx, the smallest economic order quantity is defined by purchasing and logistics in cooperation with supplier.
3.	Call off (LAB) / purchase orders If 1. and 2. are not applicable, then concept 3. has to be applied.	DAP "Place" only if there is no BOSCH contract existing for forwarding and / or type of goods are not included in BOSCH contract, e.g. dangerous goods	According to tax rules and legislations	According to customs rules and legislations	(1) Payment by invoice (2) If legally possible: self-billing invoice SBI (GAV)	Classic EDI or Web-EDI: - Transfer demand process (scheduling agreement release or Purchase order) - Advanced Shipping notification (ASN) (incl. - among others - packaging data) via Classic EDI or Web-EDI -->Refer to the "Message Implementation Guideline: GLOBAL DESADV") Labeling: Delivery of goods only in combination with codes (barcode/RFID tag) via label acc. to the GB / regional standard --> for further details see EDI-contract and supplier manual logistics			

Figure 11: Standard delivery concepts

No.	Procurement Control Concept	Frequency of delivery	Order type	Transport radius/ cycle	Mode of Transportation	Packaging		Supplier clarifies additional regulations and requirements with customer plant
						Type	Ownership	
1.	<p>KANBAN</p> <p>- Ship to Supermarket/STL (Ship to Line), from local supplier plant or from local supplier warehouse - if possible is the preferred concept</p>	High frequent delivery	Kanban (SAP-Kanban, eKanban: JIT-Call; etc.)	allowing high frequent deliveries considering cost, lot size, returnables, etc.	TMC if in place else: Milkrun or forwarder according to frame contract --> for details see supplier manual logistic	<p>Preferred: Overseas suppliers one way</p> <p>Else: Returnables (standard Bosch (VDA) concept) if TCO beneficial</p> <p>Generally: Packaging specification with Bosch plant - supplier release mandatory. Stackability per pallet at least 1+1.</p> <p>Refer to Supplier Manual Logistics for more details on packaging specification / responsibilities.</p>	Returnables Unless otherwise agreed,	
2.	<p>VMI/Consignment -</p> <p>If KANBAN is not applicable, concept 2. VMI/Consignment is preferred</p>	n.a.	<p>VMI</p> <p>Inventory information (stock movements, stock levels) and gross demand are given to supplier via Classic EDI or WebEDI (SupplyOn VMI module)</p> <p>Supply based on dynamically set MIN/MAX level and rolling forecast figures.</p> <p>In special circumstances: Call - off 's may be agreed</p>		TMC if in place else: FCA: Forwarder according to frame contract DAP/DDP: supplier transport --> for details see supplier manual logistic	<p>Preferred: Overseas suppliers one way</p> <p>Else: Returnables (standard Bosch (VDA) concept) if TCO beneficial</p> <p>Generally: Packaging specification with Bosch plant - supplier release mandatory. Stackability per pallet at least 1+1.</p> <p>Refer to Supplier Manual Logistics for more details on packaging specification / responsibilities.</p>	<p>returnables are covered by BOSCH up to a defined level of 3 days stock at supplier's warehouse (excluding transit stock). Account management and monthly balancing for returnables is mandatory for supplier - Bosch plant relation.</p> <p>One way: One way packaging is procured and paid by supplier.</p>	<p>for example:</p> <ul style="list-style-type: none"> - Time frame for pick up (TMC) - Time window reception - Mixed load - Packaging - Process "returnable packaging" - Labelling (of samples) - Kind of unloading (rear/side) - ... <p>For further specifics see supplier manual logistic</p>
3.	<p>Call off (LAB) / purchase orders</p> <p>If 1. and 2. are not applicable, then concept 3. has to be applied.</p>	Deliveries in alignment to TMC (if applicable)	<p>SAP call off (LAB) - incl. rolling forecast via SAP order</p> <p>in particular cases Purchase orders can be used - for e.g.: samples orders, operating supplies or machine accessories / replacement parts</p>	n.a.				

Figure 12: Standard delivery concepts continued

10.2 Appendix 2: Transport Order (TO)

TOs consist of order information, transport, as well as packaging and part number data. By clicking on a TO number in the order or transport list, you are forwarded to the detailed view. The TO mask is divided into the following 5 (five) parts.

Order processing

Status: open
Fields marked with * are obligatory

Service: Road Freight | Contact: Support, +55 (19) 2103 1767

Order no.*: [generated number] | Reference no.:

Purchase order no. | Delivery note no.:

Business case* | Freight mode:

Service-level*: Standard | Client:

Special cargo no. | Latest release:

Export declaration no. | Latest TO update:

Update required: | Shipment no.:

Consignor | Pickup | Recipient | Delivery | TO Owner | Principal

Customer ID | Contact person:

Company* | Phone:

| Fax:

Loading / unloading place | eMail:

Street* | State/Province:

Country / ZIP / City* |

Legs | Scheduling pool

No	Status	Load no.	Transport	Dispatch point	via Hub	Service provider	Service	Service-Level	EQD	Container-ID
Transport information										
Loading reference		Pickup date*		from		to				
Incoterm*		Destination		Delivery date*		from		to		
Comment										

Handling Units	Total pkgs.	Total gross [kg]	Total volume [m ³]	Level						
Pos	Handling Unit ID*	Description*	Qty* Type*	Gross* [kg]	Vol.* [m ³]	L* [mm]	W* [mm]	H* [mm]	Stack.*	Remark
1			CLL							

Article data

Pos	Part no.*	Goods description*	Quantity*	Unit*	Net [kg]	Origin	UN no.	Dangerous goods

Figure 13: Example of TO

1. General order details and transport references
2. Address information
3. Transport details and times
4. Packaging information
5. Article information (optional)

Fields marked with an asterisk (*) are mandatory.

10.3 Appendix 3: Label

10.3.1 Introduction

According to VDA rules, the following standards are specified for the automotive industry and its suppliers. Labels complying with VDA 4902 are the standard in Europe (ODETTE), the USA and Canada (AIAG) and can be used for all international supply chains.

Main packaging taking into account the following structure

- Main packaging: Pallet, pallet cage
- Secondary packaging: SLC, carton ...

These two variations are described below and are to be used as set out in this supplier manual.

The main product tag for main packaging (pallet, pallet cage)

- Adhesive labels, white background, size 210 x 148 mm
- Two labels must be on the container, one on the front and one on the longitudinal side.
- The content of the label must be printed in "Arial" or a similar font.
- The printing must be in black.
- Details below (example label).

Secondary products tags for SLC, cardboard

- Label, white background, size 210 x 74 mm
- It must be positioned on the front of each SLC.
- The content of the label must be printed in "Arial" or a similar font.
- The printing must be in black.

Details on the following pages (example label).

10.3.2 Labeling standards in compliance with VDA 4902/ODETTE

210		148
(1) Conesnee, full addr. AUTOMOTIVE SUPPLIER AG D-80000 MUENCHEN 40		(2) Unloading point - Warehouse - Usage Code FAST'n FURIOUS GMBH - SPEDITION ECHING B. MUENCHEN
(3) Advice Note No (N) IA014694 	(4) Consignor /ship from NO-ROST STAHL AG ZINCAL-WERK	
(5) Net weight 10310		(6) Gross weight 10340
(7) Number of packages 2250		
(8) Part number Customer (P) 0 166 496 		
(9) Quantity / package (Q) 24 	ST	(10) Part Description RR ST 13 05 MONOZINC
(11) Part number Supplier (30S) 123456789 		(12) Consignor no (V) 57349611 
(13) Date (prod./ shipment /) P 901016		(14) Engineering Revision 14
(15) Label Serial No (S) 103000103 		(16) Batch no (H) 1481781001 
(17) NO-ROST STAHL AG ZINCAL-WERK Warenanhaenger VDA 4902, Version 4		

Figure 14: Main product label for original packaging (pallet, pallet cage) / The content of the label is shown as an example

Fields and barcode description on main product tag

The serial number (see example in section 15 in Fig. 13) is numerical and uniquely identifies the package within a year. It is assigned to each package by the SUPPLIER and should only be used once a year.

The serial numbers must always be specified in VDA 4913 (EDI) and on shipping documents or delivery note, and these must match. The characters must be at least 5 mm high. The serial number barcode must be directly underneath the numerical number that can be read by people (see example). The maximum length of the serial number must be 9 numerical characters plus the identifier (S, M, or G).

The S, M, or G identifiers are as follows:

- (S) Packages with no secondary packaging.
- (M) Loading unit with single serial number.
- (G) Mixed loading unit / pallet.

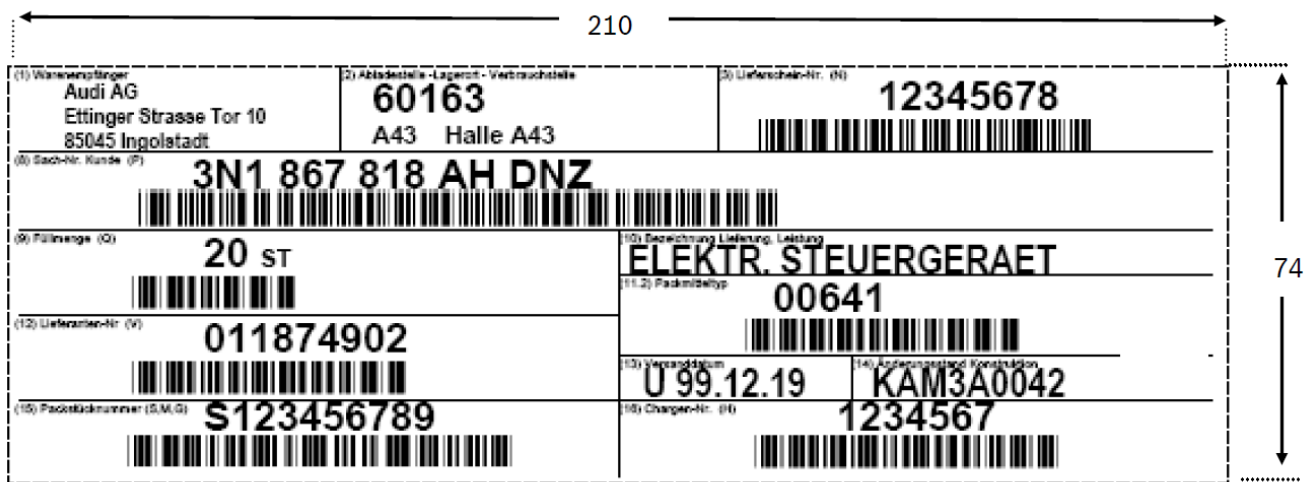

Figure 15: Secondary labels for secondary packaging (SLC, carton ...) / The content of the label is shown as an example.

Field Nr.	Field Name	Compulsory / Optional	Barcode
1	Receiver Name	C	No
2	Unloading Site	C	No
3	Delivery Note Nr / ASN (N)	C	Yes
4	Supplier short address	C	No
5	Net weight	O	No
6	Gross weight	O	No
7	Number of packages	C	No
8	Customer part number (P)	C	Yes
9	Quantity (Q)	C	Yes
10	Description	C	No
11	Supplier reference number	O	No
12	Supplier number /code (V)	C	Yes
13	Date of shipment	C	No
14	Engineering Revision (2P)	C	Yes
15	Label serial number (S)	C	Yes
16	Batch Number (H)	C	Yes

C: Compulsory

O: Optional

Figure 16: Binding and optional fields



Robert Bosch GmbH

CP/LOG-S

Corporate Sector Purchasing and Logistics

Postfach 30 02 20

70442 Stuttgart

Germany

bosch.logistics@de.bosch.com

Edition: 4.0. 2016